



User Guide

SI-Encoder

Part Number: 0478-0127-02
Issue: 2

Original Instructions

For the purposes of compliance with the EU Machinery Directive 2006/42/EC, the English version of this manual is the Original Instructions. Manuals in other languages are Translations of the Original Instructions.

Documentation

Manuals are available to download from the following locations: <http://www.drive-setup.com/ctdownloads>

The information contained in this manual is believed to be correct at the time of printing and does not form part of any contract. The manufacturer reserves the right to change the specification of the product and its performance, and the contents of the manual, without notice.

Warranty and Liability

In no event and under no circumstances shall the manufacturer be liable for damages and failures due to misuse, abuse, improper installation, or abnormal conditions of temperature, dust, or corrosion, or failures due to operation outside the published ratings. The manufacturer is not liable for consequential and incidental damages. Contact the supplier of the drive for full details of the warranty terms.

Environmental policy

Control Techniques Ltd operates an Environmental Management System (EMS) that conforms to the International Standard ISO 14001.

Further information on our Environmental Policy can be found at: <http://www.drive-setup.com/environment>

Restriction of Hazardous Substances (RoHS)

The products covered by this manual comply with European and International regulations on the Restriction of Hazardous Substances including EU directive 2011/65/EU and the Chinese Administrative Measures for Restriction of Hazardous Substances in Electrical and Electronic Products.

Disposal and Recycling (WEEE)



When electronic products reach the end of their useful life, they must not be disposed of along with domestic waste but should be recycled by a specialist recycler of electronic equipment. Control Techniques products are designed to be easily dismantled into their major component parts for efficient recycling. The majority of materials used in the product are suitable for recycling.

Product packaging is of good quality and can be re-used. Large products are packed in wooden crates. Smaller products are packaged in strong cardboard cartons which have a high recycled fibre content. Cartons can be re-used and recycled. Polythene, used in protective film and bags for wrapping the product, can be recycled. When preparing to recycle or dispose of any product or packaging, please observe local legislation and best practice.

REACH legislation

EC Regulation 1907/2006 on the Registration, Evaluation, Authorisation and restriction of Chemicals (REACH) requires the supplier of an article to inform the recipient if it contains more than a specified proportion of any substance which is considered by the European Chemicals Agency (ECHA) to be a Substance of Very High Concern (SVHC) and is therefore listed by them as a candidate for compulsory authorisation.

Further information on our compliance with REACH can be found at: <http://www.drive-setup.com/reach>

Registered Office

Nidec Control Techniques Ltd
The Gro
Newtown
Powys
SY16 3BE
UK

Registered in England and Wales. Company Reg. No. 01236886.

Copyright

The contents of this publication are believed to be correct at the time of printing. In the interests of a commitment to a policy of continuous development and improvement, the manufacturer reserves the right to change the specification of the product or its performance, or the contents of the guide, without notice.

All rights reserved. No parts of this guide may be reproduced or transmitted in any form or by any means, electrical or mechanical including photocopying, recording or by an information storage or retrieval system, without permission in writing from the publisher.

Copyright © January 2018 Nidec Control Techniques Ltd

Contents

1	How to use this guide	5
1.1	Intended personnel	5
1.2	Information	5
2	Safety information	6
2.1	Important safety information. Hazards. Competence of designers and installers	6
2.2	Responsibility	6
2.3	Compliance with regulations	6
2.4	Electrical hazards	7
2.5	Stored electrical charge	7
2.6	Mechanical hazards	7
2.7	Access to equipment	7
2.8	Environmental limits	8
2.9	Hazardous environments	8
2.10	Motor	8
2.11	Mechanical brake control	8
2.12	Adjusting parameters	8
2.13	Electromagnetic compatibility (EMC)	8
3	Introduction	9
3.1	Features	9
3.2	Option module identification	9
3.3	Set-up parameters	9
3.4	Compatible encoder types	10
4	Installing the option module	11
4.1	General installation	11
5	Electrical installation	12
5.1	Terminal descriptions	12
5.2	Wiring, Shield connections	12
6	Getting started	17
6.1	Installation	17
6.2	SI-Encoder set-up	18
6.3	Termination resistors	18
7	Parameters	19
7.1	Menus	19
7.2	Single line descriptions	20
7.3	Parameter descriptions	21
8	Diagnostics	34
8.1	Overview	34
9	Terminal data	36
9.1	Encoder inputs	36

1 How to use this guide

1.1 Intended personnel

This guide is intended for personnel who have the necessary training and experience in system design, installation, commissioning and maintenance.

1.2 Information

This guide contains information covering the identification of the option module, terminal layout for installation, installation of the option module to the drive, parameter details and diagnosis information. Additional to the aforementioned are the specifications of the option module.

How to use
this guide

Safety
Information

Introduction

Installing the
option module

Electrical
Installation

Getting started

Parameters

Diagnostics

Terminal data

Index

2 Safety information

2.1 Warnings, Cautions and Notes



A Warning contains information which is essential for avoiding a safety hazard.



A Caution contains information which is necessary for avoiding a risk of damage to the product or other equipment.



A Note contains information, which helps to ensure correct operation of the product.

2.2 Important safety information. Hazards. Competence of designers and installers

This guide applies to products which control electric motors either directly (drives) or indirectly (controllers, option modules and other auxiliary equipment and accessories). In all cases the hazards associated with powerful electrical drives are present, and all safety information relating to drives and associated equipment must be observed.

Specific warnings are given at the relevant places in this guide.

Drives and controllers are intended as components for professional incorporation into complete systems. If installed incorrectly they may present a safety hazard. The drive uses high voltages and currents, carries a high level of stored electrical energy, and is used to control equipment which can cause injury. Close attention is required to the electrical installation and the system design to avoid hazards either in normal operation or in the event of equipment malfunction. System design, installation, commissioning/start-up and maintenance must be carried out by personnel who have the necessary training and competence. They must read this safety information and this guide carefully.

2.3 Responsibility

It is the responsibility of the installer to ensure that the equipment is installed correctly with regard to all instructions given in this guide. They must give due consideration to the safety of the complete system, so as to avoid the risk of injury both in normal operation and in the event of a fault or of reasonably foreseeable misuse.

The manufacturer accepts no liability for any consequences resulting from inappropriate, negligent or incorrect installation of the equipment.

2.4 Compliance with regulations

The installer is responsible for complying with all relevant regulations, such as national wiring regulations, accident prevention regulations and electromagnetic compatibility (EMC) regulations. Particular attention must be given to the cross-sectional areas of conductors, the selection of fuses or other protection, and protective ground (earth) connections.

This guide contains instructions for achieving compliance with specific EMC standards.

All machinery to be supplied within the European Union in which this product is used must comply with the following directives:

2006/42/EC Safety of machinery.

2014/30/EU: Electromagnetic Compatibility.

2.5 Electrical hazards

The voltages used in the drive can cause severe electrical shock and/or burns, and could be lethal. Extreme care is necessary at all times when working with or adjacent to the drive. Hazardous voltage may be present in any of the following locations:

- AC and DC supply cables and connections
- Output cables and connections
- Many internal parts of the drive, and external option units

Unless otherwise indicated, control terminals are single insulated and must not be touched.

The supply must be disconnected by an approved electrical isolation device before gaining access to the electrical connections.

The STOP and Safe Torque Off functions of the drive do not isolate dangerous voltages from the output of the drive or from any external option unit.

The drive must be installed in accordance with the instructions given in this guide. Failure to observe the instructions could result in a fire hazard.

2.6 Stored electrical charge

The drive contains capacitors that remain charged to a potentially lethal voltage after the AC supply has been disconnected. If the drive has been energized, the AC supply must be isolated at least ten minutes before work may continue.

2.7 Mechanical hazards

Careful consideration must be given to the functions of the drive or controller which might result in a hazard, either through their intended behaviour or through incorrect operation due to a fault. In any application where a malfunction of the drive or its control system could lead to or allow damage, loss or injury, a risk analysis must be carried out, and where necessary, further measures taken to reduce the risk - for example, an over-speed protection device in case of failure of the speed control, or a fail-safe mechanical brake in case of loss of motor braking.

With the sole exception of the Safe Torque Off function, none of the drive functions must be used to ensure safety of personnel, i.e. they must not be used for safety-related functions.

The Safe Torque Off function may be used in a safety-related application. The system designer is responsible for ensuring that the complete system is safe and designed correctly according to the relevant safety standards.

The design of safety-related control systems must only be done by personnel with the required training and experience. The Safe Torque Off function will only ensure the safety of a machine if it is correctly incorporated into a complete safety system. The system must be subject to a risk assessment to confirm that the residual risk of an unsafe event is at an acceptable level for the application.

2.8 Access to equipment

Access must be restricted to authorized personnel only. Safety regulations which apply at the place of use must be complied with.

2.9 Environmental limits

Instructions in this guide regarding transport, storage, installation and use of the equipment must be complied with, including the specified environmental limits. This includes temperature, humidity, contamination, shock and vibration. Drives must not be subjected to excessive physical force.

2.10 Hazardous environments

The equipment must not be installed in a hazardous environment (i.e. a potentially explosive environment).

2.11 Motor

The safety of the motor under variable speed conditions must be ensured.

To avoid the risk of physical injury, do not exceed the maximum specified speed of the motor.

Low speeds may cause the motor to overheat because the cooling fan becomes less effective, causing a fire hazard. The motor should be installed with a protection thermistor. If necessary, an electric forced vent fan should be used.

The values of the motor parameters set in the drive affect the protection of the motor. The default values in the drive must not be relied upon. It is essential that the correct value is entered in the Motor Rated Current parameter.

2.12 Mechanical brake control

Any brake control functions are provided to allow well co-ordinated operation of an external brake with the drive. While both hardware and software are designed to high standards of quality and robustness, they are not intended for use as safety functions, i.e. where a fault or failure would result in a risk of injury. In any application where the incorrect operation of the brake release mechanism could result in injury, independent protection devices of proven integrity must also be incorporated.

2.13 Adjusting parameters

Some parameters have a profound effect on the operation of the drive. They must not be altered without careful consideration of the impact on the controlled system.

Measures must be taken to prevent unwanted changes due to error or tampering.

2.14 Electromagnetic compatibility (EMC)

Installation instructions for a range of EMC environments are provided in the relevant Power Installation Guide. If the installation is poorly designed or other equipment does not comply with suitable standards for EMC, the product might cause or suffer from disturbance due to electromagnetic interaction with other equipment. It is the responsibility of the installer to ensure that the equipment or system into which the product is incorporated complies with the relevant EMC legislation in the place of use.

3 Introduction

3.1 Features

The SI-Encoder option module provides an interface for connecting an AB quadrature encoder to the drive, to be used as position and speed feedback for the drive. Typical uses for this option module would be to provide a speed feedback interface for motor control or to input speed a speed/position reference from a line speed encoder.

3.2 Option module identification

The SI-Encoder can be identified by:

1. The label located on the topside of the option module.
2. The color coding across the front of the option module: light brown.

Figure 3-1 SI-Encoder label

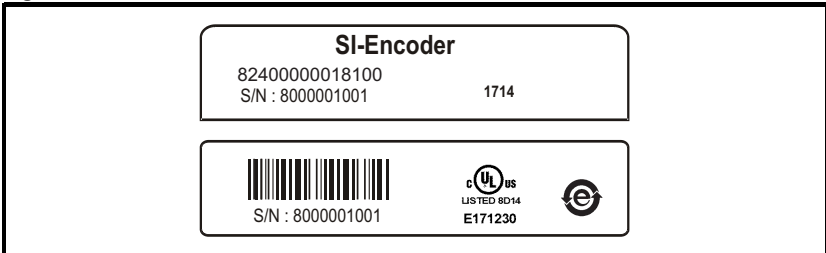

3.2.1 Date code format

Date code format

The date code is four numbers. The first two numbers indicate the year and the remaining numbers indicate the week of the year in which the drive was built.

Example:

A date code of 1710 would correspond to week 10 of year 2017.

3.3 Set-up parameters

All parameters associated with the SI-Encoder can be found in either menu 15, 16, or 17. Each of menus 15, 16, and 17 refer to one of the available slots into which the option module can be fitted. Slot 1 = Menu 15, Slot 2 = Menu 16, Slot 3 = Menu 17.

3.4 Compatible encoder types

The SI-Encoder module is compatible with incremental AB encoders without a marker pulse.

Incremental encoders AB without marker pulse

This type of encoder gives incremental position and its intended use is for motor control in RFC-A mode. It can also be used for motor control in RFC-S mode, although no communication signals are present, so a phasing autotune must be performed when the drive powers up initially or after an encoder trip.

Type	Encoder	Description
Incremental	AB	Quadrature incremental encoder. Without marker pulse.

Quadrature detection logic determines rotation from the phase relationship of the two channels.

Limitations			
Type	Encoder	Max Input Frequency	Max no. of Lines (LPR)
Incremental	AB	500 kHz*	65,536

*Max input frequency = LPR x rpm / 60

NOTE The maximum speed in rpm which an encoder connected to the SI-Encoder can reach can be calculated from :

$$\text{Max rpm} = (60 \times \text{Max input frequency}) / \text{Encoder LPR}$$

e.g. For a 4096 line encoder the maximum rpm would be:

$$(60 \times 500 \times 10^3) / 4096 = 7324 \text{ rpm}$$

Figure 3-2 Encoder feedback signals

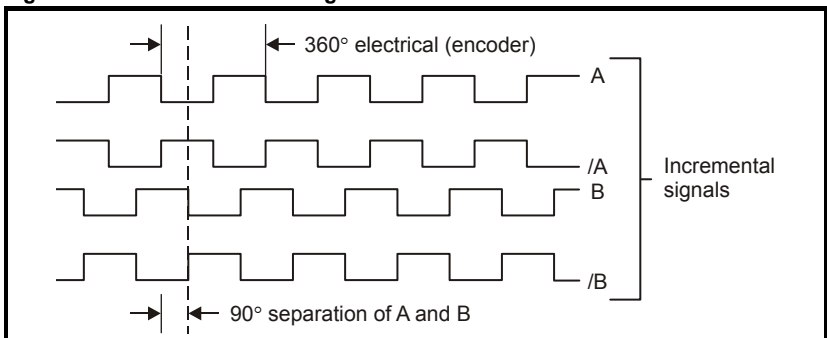

NOTE Only encoders with lines per revolution that are a power of 2 can be used with the SI-Encoder, e.g. 256, 512, 1024 etc.

3.4.1 Drive firmware compatibility

The SI-Encoder module is compatible with the Unidrive M600 to M702 range of drives. The recommended drive firmware version is V01.08.00.00 or later.

4 Installing the option module



Before installing or removing an option module from any drive, ensure the AC supply has been disconnected for at least 10 minutes and refer to Chapter 2 *Safety information* on page 6. If using a DC bus supply ensure this is fully discharged before working on any drive or option module

4.1 General installation

Installation of an option module is illustrated in Figure 4-1.

Figure 4-1 Installing an option module

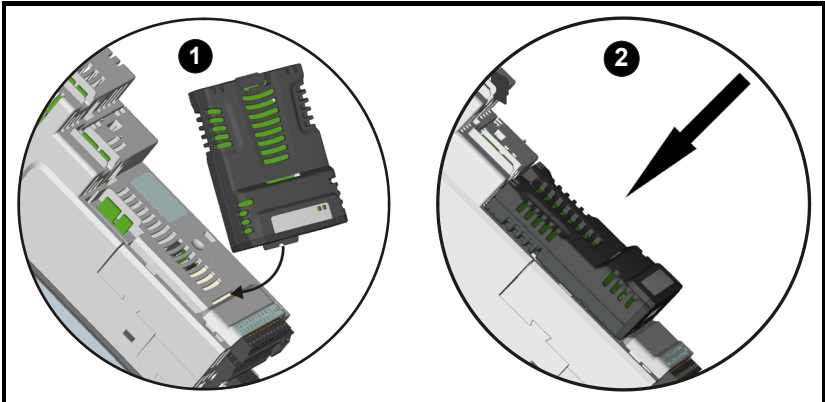

- Option module slots must be used in the following order: slot 3 (lower), slot 2 (middle) and slot 1 (upper).
- Orientate the option module above the drive as shown (1) in the first image above.
- Align and insert the option module tab into the slot and press down until the option module locks into place.

NOTE Option modules can only be installed on drives that have the option module slot functionality as shown in Figure 4-1 above.

5 Electrical installation

5.1 Terminal descriptions

Figure 5-1 SI-Encoder terminals



Table 5-1 SI-Encoder terminal descriptions

Terminal	Encoder inputs
	AB
1	A
2	A\
3	B
4	B\
5	+V
6	0V
7	0V

5.2 Wiring, Shield connections

Shielding considerations are important for PWM drive installations due to the high voltages and currents present in the output circuit with a very wide frequency spectrum, typically from 0 to 20 MHz. Encoder inputs are liable to be disturbed if careful attention is not given to managing the cable shields.

Encoder mounting methods

There are three methods for mounting an encoder onto a motor:

1. Galvanic isolation between encoder and motor
2. Galvanic isolation between encoder circuit and encoder body
3. No isolation

5.2.1 Encoder with galvanic isolation from motor

When galvanically isolated the encoder device is mounted to the motor with isolation fitted between the motor housing / shaft and encoder as shown in Figure 5-2.

Figure 5-2 Galvanic Isolation

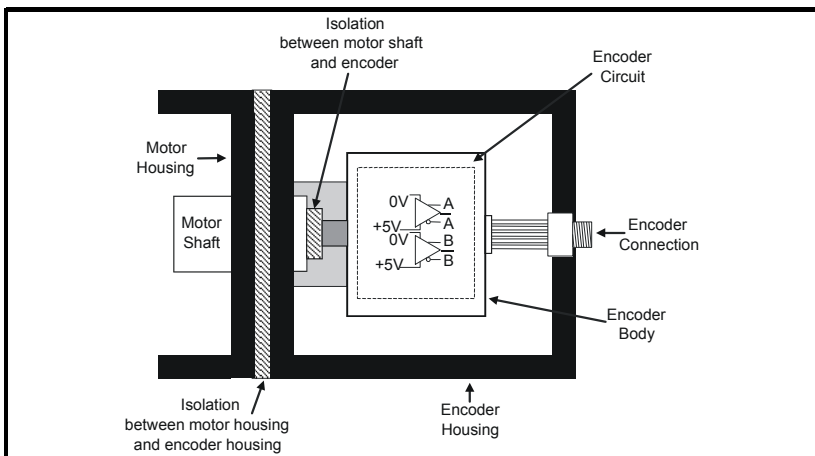

An example of this is the Unimotor, where isolation from the motor is achieved by inserting a plastic mounting plate between the motor housing and encoder housing and a plastic insert fitted in the motor shaft for encoder mounting to the motor shaft. With this preferred method of mounting, noise current is prevented from passing from the motor housing into the encoder housing, and hence into the encoder cable. The ground connection of the cable shield is optional, this may be required to comply with safety measures or to reduce radiated radio frequency emissions from either the drive or encoder.

5.2.2 Encoder circuit with galvanic isolation from encoder body

In this case, the encoder device is mounted directly on the motor housing with contact being made between the motor housing/shaft and encoder. With this mounting method, the encoders internal circuits are exposed to electrical noise from the motor housing through the stray capacitance, and must therefore be designed to withstand this situation. However, this arrangement still prevents large noise currents from flowing from the motor body into the encoder cable.

The ground connection of the cable shield is optional, this may be required to comply with safety measures or to reduce radiated radio frequency emissions from either the drive or encoder.

Figure 5-3 Encoder galvanically isolated from encoder body

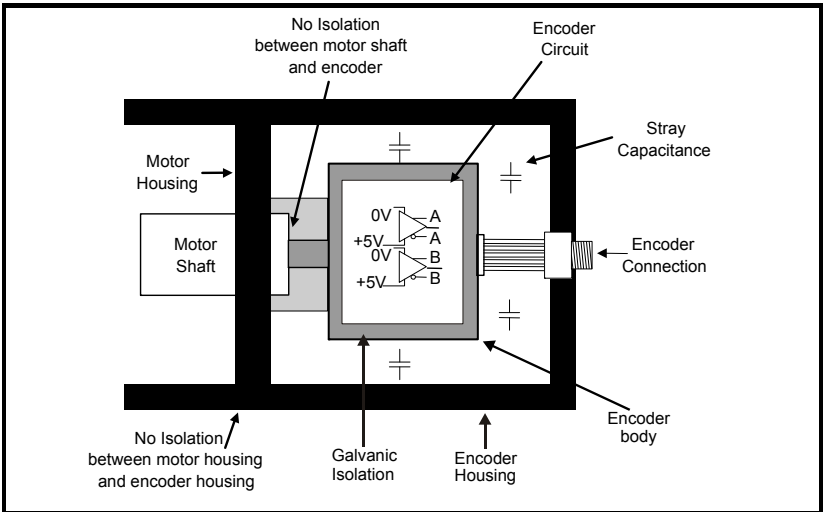

5.2.3 No isolation

As shown in Figure 5-4 the encoder 0 V connection may be permanently connected to the housing. This has the advantage that the encoder body can form a shield for its internal circuits. However it permits noise current from the motor body to flow into the encoder cable shield. A good quality shielded cable correctly terminated protects the data against this noise current, but much more care is needed in ensuring correct cable management than for the isolated cases.

Figure 5-4 No isolation

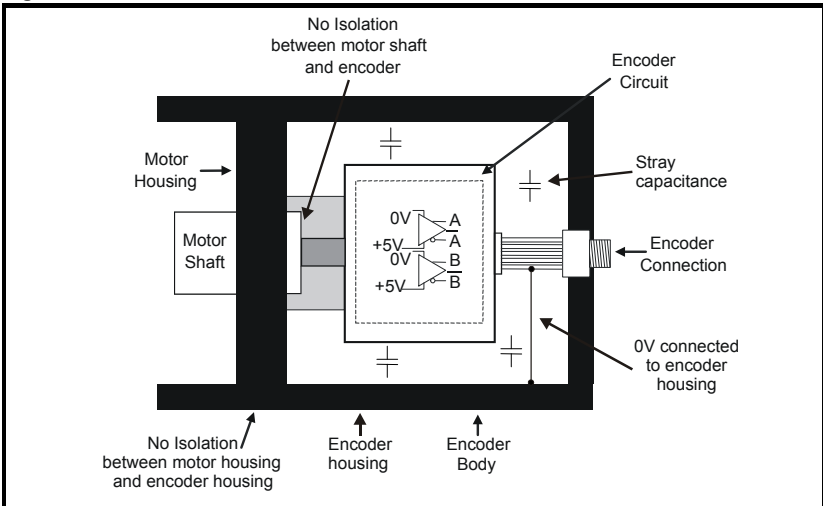

5.2.4 Cable requirements

All mounting methods:

- Shield connection at drive terminal to 0V
- Shield connection at encoder to 0V
- It is recommended that the shielded cable should be run in a continuous length to the terminal, to avoid the injection of noise at intermediate pigtails and to maximise the shielding benefit.
- The shield connections ("pigtailed") to the drive and encoder should be kept as short as possible

Mounting with no isolation:

- Shield connected to ground at both ends. The connection must be made by direct fixing of the cable to the grounded metal parts, i.e. to the encoder body and the drive grounding bracket, as illustrated in Figure 4.9. "Pigtails" must be avoided. The outer sheath of the cable should be stripped back enough to allow for the ground clamp to be installed. The shield connection should not be broken. The ground clamps should be located as close as possible to the drive and encoder.
- It is essential that the shielded cable should be run in a continuous length to the terminal, to avoid the injection of noise at intermediate "pigtailed" and to maximise the shielding benefit.



In this case under no circumstances must the cable shield connection be omitted at either end of the cable in this case, since the noise voltage may well be sufficient to destroy the line driver and receiver chips in the encoder and the drive.

Cable shield ground connection

For all mounting methods, grounding of the feedback cable shield has added benefits. It can protect the drive and encoder from induced fast electrical transients, and prevent radiated radio-frequency emission. However it is essential that it be carried out in the correct manner as explained above and shown in Figure 5-6.



Connecting the cable shield to ground at both ends carries the risk that an electrical fault might cause excessive power current to flow in the cable shield and overheat the cable. There must be an adequately rated safety ground connection between the motor/encoder and the drive.

Recommended Cable

The recommended cable for feedback signals is a twisted pair, shielded with an overall shield as shown below.

Figure 5-5 Feedback cable, twisted pair

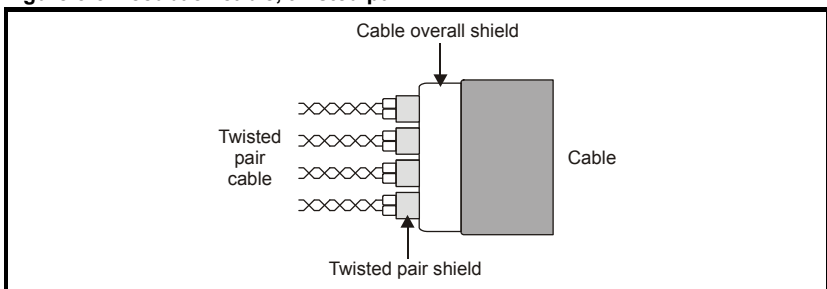

Using this type of cable also allows for the connection of the outer shield to ground and the inner shields to 0 V alone at both drive and encoder end, when required.

NOTE

Ensure that feedback cables are kept as far away as possible from power cables and avoid parallel routing.

Figure 5-6 Feedback cable connections

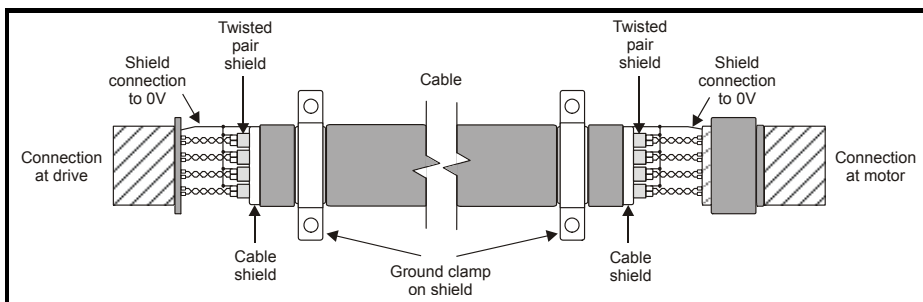

6 Getting started

6.1 Installation



The control circuits are isolated from the power circuits in the drive by basic insulation only, as specified in IEC60664-1. The installer must ensure that the external control circuits are insulated from human contact by at least one layer of insulation rated for use at the AC supply voltage.

If the control circuits are to be connected to other circuits classified as Safety Extra Low Voltage (SELV) (e.g. to a personal computer) an additional isolating barrier must be included in order to maintain the SELV classification.

Encoder connections

In order to ensure correct operation there are a number of checks which should be carried out:

- Ensure the encoder is securely mounted to the motor as spurious operation can result due to the encoder slipping whilst the motor is rotating.
- Ensure encoder connections to both the encoder and the option module terminals are secured, intermittent connections can result in spurious operation or the option module not detecting the feedback signals.
- Ensure shielding recommendations as specified in section 5.2 *Wiring, Shield connections* are followed to prevent noise being induced on the encoder feedback signals. Noise induced on encoder feedback cables cannot only result in spurious operation but in extreme cases can result in encoder failure and/or damage to the option modules encoder input.

Encoder feedback is transmitted from an encoder as low voltage digital signals. Ensure that electrical noise from the drive or motor does not adversely affect the encoder feedback. Ensure that the drive and motor are connected as per the instructions given in the appropriate drive manual, and that the encoder feedback wiring and shielding recommendations are followed in section 5.2 *Wiring, Shield connections* on page 12.

6.2 SI-Encoder set-up

To set-up the SI-Encoder module the following parameter settings should be made.

Action	Detail
Before power-up	Ensure: <ul style="list-style-type: none"> • Drive SAFE TORQUE OFF is not given • Run signal is not given • Option module is installed in appropriate slot • Feedback device is connected
Power up drive	Ensure: <ul style="list-style-type: none"> • Drive displays 'Inhibit' If the drive trips see Chapter 8 Diagnostics on page 29 or refer to the diagnostic section in the <i>Drive User Guide</i> .
Slot identification	Identify which option module slot and menu are being used <ul style="list-style-type: none"> • Slot 1 – Menu 15 • Slot 2 – Menu 16 • Slot 3 – Menu 17
Set-up encoder power supply	Enter: <ul style="list-style-type: none"> • Encoder power supply Pr MM.036 0: 5V, 1: 8V, 2: 15V
Set-up encoder lines per revolution	Enter: <ul style="list-style-type: none"> • Lines per revolution Pr MM.034 Set according to the lines per revolution of the encoder. This must be a power of 2.
Initialization	Ensure: <ul style="list-style-type: none"> • Module Status Pr MM.006 shows "OK" If the SI-Encoder module is configured then the relevant bit in <i>Position Feedback Initialized</i> Pr 03.076 will be set to 1.
Select the option as the source for motor control feedback	If the encoder connected to the SI-Encoder module is to be used for motor control feedback, ensure that Pr 03.026 is set correctly. Valid settings for Pr 03.026 are shown below. <ul style="list-style-type: none"> • Speed feedback selector Pr 03.026 2: P1 Slot1 4: P1 Slot2 6: P1 Slot3

6.3 Termination resistors

By default the termination resistors on the encoder inputs are enabled. The termination resistors can be configured as shown below using encoder termination Pr **MM.039**.

Terminal	Encoder Input	Pr MM.039=0	Pr MM.039=1
1, 2	A, A\	Disabled	Enabled
3, 4	B, B\	Disabled	Enabled

The termination resistance when connected is 120 Ω in total.

7 Parameters

7.1 Menus

The module's menu is displayed in menu 15, 16 or 17 depending on which slot the module is installed in. Table 7-1 below shows the location of the module's menu on the drive.

Table 7-1 Menu location

Slot Number	Menu location
1	15
2	16
3	17

7.2 Single line descriptions

Parameter		Range (↕)	Default (⇒)	Type					
MM.001	Module ID	0 to 65535	105	RO	Num	ND	NC	PT	
MM.002	Software Version	00.00.00.00 to 99.99.99.99		RO	Ver	ND	NC	PT	
MM.003	Hardware Version	00.00 to 99.99		Num	Ver	ND	NC	PT	
MM.004	Serial Number LS	0 to 99999999		RO	Num	ND	NC	PT	
MM.005	Serial Number MS	0 to 99999999		RO	Num	ND	NC	PT	
MM.006	Module Status	Initializing (0), OK (1), Config (2), Error (3)		RO	Txt	ND	NC	PT	
MM.024	Module Temperature	-128 to 127 °C		RO	Num	ND	NC	PT	
MM.025	Slot Indicator	0 to 8		RO	Num	ND	NC	PT	
MM.026	Slot Menu Number	0 to 255		RO	Num	ND	NC	PT	
MM.027	Speed Feedback	-2 ³¹ to 2 ³¹ -1 rpm		RO	Num	ND	NC	PT	
MM.028	Revolution Counter	0 to 65535		RO	Num	ND	NC	PT	
MM.029	Position	0 to 65535		RO	Num	ND	NC	PT	
MM.030	Fine Position	0 to 65535		RO	Num	ND	NC	PT	
MM.033	Turns Bits	0 to 16	16	RW	Num				US
MM.034	Lines Per Revolution	1 to 100000	1024	RW	Num				US
MM.036	Supply Voltage	5 V (0), 8 V (1), 15 V (2)	5 V (0)	RW	Txt				US
MM.039	Termination Select	0 to 1	1	RW	Num				US
MM.040	Error Detection Level	00 to 11	01	RW	Bin				US
MM.042	Feedback Filter	Disabled (0), 1 ms (1), 2 ms (2), 4 ms (3), 8 ms (4), 16 ms (5)	Disabled (0)	RW	Txt				US
MM.043	Maximum Reference	0 to 50000	1500	RW	Num				US
MM.044	Reference Scaling	0.000 to 4.000	1	RW	Num				US
MM.045	Reference	±100.0 %		RO	Num	ND	NC	PT	
MM.046	Reference Destination	0.000 to 59.999	0.000	RW	Num	DE		PT	US
MM.050	Feedback Lock	Off (0) or On (1)	Off (0)	RW	Bit				US
MM.056	Feedback Reverse	Off (0) or On (1)	Off (0)	RW	Bit				US
MM.057	Normalization Turns	0 to 16	16	RW	Num				US
MM.058	Normalized Position	-2 ³¹ to 2 ³¹ -1		RO	Num	ND	NC	PT	
MM.070	Position Feedback Signals	000000 to 111111		RO	Bin	ND	NC	PT	
MM.071	Error Detected	Off (0) or On (1)		RO	Bit	ND	NC	PT	

7.3 Parameter descriptions

MM.001		Module ID	
Minimum	0	Maximum	65535
Default	105	Units	
Type	16 Bit Volatile	Update Rate	Power-up write
Display Format	None	Decimal Places	0
Coding	RO, ND, NC, PT, BU		

Pr **MM.001** displays the ID number for the option module. For the SI-Encoder module this is 105.

MM.002		Firmware version	
Minimum	0 (Display 00.00.00.00)	Maximum	99999999 (Display 99.99.99.99)
Default		Units	
Type	32 Bit Volatile	Update Rate	Power-up write
Display Format	Version Number	Decimal Places	0
Coding	RO, ND, NC, PT		

Pr **MM.002** displays the firmware version of the option module is in the format of **ww.xx.yy.zz**.

MM.003		Hardware version	
Minimum	00.00	Maximum	99.99
Default		Units	
Type	16 Bit Volatile	Update Rate	Power-up write
Display Format	None	Decimal Places	2
Coding	RO, ND, NC, PT		

Pr **MM.003** displays the hardware version of the option module.

How to use this guide

Safety Information

Introduction

Installing the option module

Electrical installation

Getting started

Parameters

Diagnostics

Terminal data

Index

MM.004	Serial Number LS		
MM.005	Serial Number MS		
Minimum	0	Maximum	99999999
Default		Units	
Type	32 Bit Volatile	Update Rate	Power-up write
Display Format	None	Decimal Places	0
Coding	RO, ND, NC, PT		

The module serial number is available as a pair of 32-bit values where Serial Number LS (Pr **MM.004**) provide the least significant 8 decimal digits, and Serial Number MS (Pr **MM.005**) provides the most significant 8 decimal digits. The reconstructed serial number is ((Pr **MM.005** x 100000000) + Pr **MM.004**). For example serial number "0001234567898765" would be stored as Pr **MM.005** = 123456 and Pr **MM.004** = 67898765.

MM.006	Module Status		
Minimum	0	Maximum	101
Default		Units	
Type	8 Bit Volatile	Update Rate	Background read
Display Format	Text	Decimal Places	0
Coding	RO, TE, ND, NC, PT		

This parameter displays the current status of the module. All possible values are shown in the table below.

Value	Text	Description
0	Initializing	Module is currently initializing.
1	Ok	Module has initialized and has found no errors.
2	Config	A configuration error has been detected in the parameter setting for the module or the module has tripped.
3	Error	An error has occurred preventing the firmware from running correctly.
100	Bootloader	The bootloader is currently running.
101	Updating	The bootloader is currently performing a firmware update. Power must not be turned off in this state.

A configuration error has been detected in the parameter setting for the module or the module has tripped.

MM.024		Module Temperature	
Minimum	-128	Maximum	127
Default	0	Units	°C
Type	8 Bit Volatile	Update Rate	Background write
Display Format	None	Decimal Places	0
Coding	RO, ND, NC, PT		

This parameter displays the current temperature of the module.

MM.025		Slot Indicator	
Minimum	0	Maximum	8
Default		Units	
Type	8 Bit Volatile	Update Rate	Written on power-up
Display Format	None	Decimal Places	0
Coding	RO, ND, NC, PT		

This parameter displays the number of the virtual option slot on the drive that the module is installed in.

MM.026		Slot Menu Number	
Minimum	0	Maximum	255
Default		Units	
Type	8 Bit Volatile	Update Rate	Written on power-up
Display Format	None	Decimal Places	0
Coding	RO, ND, NC, BU		

This parameter displays the menu number of the option slot on the drive.

e.g.

Slot 1 - Menu 15

Slot 2 - Menu 16

Slot 3 - Menu 17

MM.027		Speed Feedback	
Minimum	-2147483648	Maximum	2147483647
Default		Units	rpm
Type	32 Bit Volatile	Update Rate	4 ms write
Display Format	None	Decimal Places	1
Coding	RO, ND, NC, PT		

Provided the set-up parameters for the position feedback device connected to the position interface are correct *Speed Feedback* (Pr **MM.027**) shows the speed derived from the feedback. The speed is given in rpm. The value shown is measured over a 16 ms sliding window period

MM.028	Revolution Counter		
MM.029	Position		
MM.030	Fine Position		
Minimum	0	Maximum	65535
Default		Units	
Type	16 Bit Volatile	Update Rate	4 ms write
Display Format	None	Decimal Places	0
Coding	RO, ND, NC, PT, BU		

Revolution Counter (Pr **MM.028**), *Position* (Pr **MM.029**) and *Fine Position* (Pr **MM.030**) combined give the encoder position with a resolution of $1/2^{32}$ of a revolution as a 48 bit number. These quantities relate directly to the rotary position of the feedback device.

Provided the position feedback interface set-up parameters are correct, the position is always converted to units of $1/2^{32}$ of a revolution, but some parts of the value may not be relevant depending on the resolution of the feedback device

When the position feedback moves by more than one revolution the *Revolution Counter* (Pr **MM.028**) increments or decrements in the form of a sixteen bit roll-over counter.

MM.033	Turns Bits		
Minimum	0	Maximum	16
Default	16	Units	
Type	8 Bit User Save	Update Rate	Background read
Display Format	None	Decimal Places	0
Coding	RW		

It is sometimes desirable to mask off the most significant bits of *Revolution Counter* (Pr **MM.028**), but this does not have to be done for the drive to function correctly. If *Turns Bits* (Pr **MM.033**) = 0 the whole of *Revolution Counter* (Pr **MM.028**) is held at zero. If *Turns Bits* (Pr **MM.033**) has any other value it indicates the number of bits in *Revolution Counter* (Pr **MM.028**) that are not held at zero. For example, if *Turns Bits* (Pr **MM.033**) = 5, then *Revolution Counter* (Pr **MM.028**) counts up to 31 before being reset.

MM.034		Lines Per Revolution	
Minimum	0	Maximum	100000
Default	1024	Units	
Type	32 Bit User Save	Update Rate	Background read
Display Format	None	Decimal Places	0
Coding	RW		

This parameter should be set to the number of lines per revolution for the encoder connected to the position feedback interface.

The value entered must be a power of 2 (e.g. 512, 1024, 2048, 4096, etc). If a value which is a non-power of 2 is entered, the drive will trip with a *Slotx Error.Invalid LPR* trip.

MM.036		Supply Voltage	
Minimum	0	Maximum	2
Default	0	Units	
Type	8 Bit User Save	Update Rate	Background read
Display Format	None	Decimal Places	0
Coding	RW, TE		

Value	Text
0	5 V
1	8 V
2	15 V

Supply Voltage (Pr **MM.036**) sets the level for the supply voltage output. To ensure that the maximum voltage for the position feedback device is not accidentally exceeded, the device should be disconnected from the module when the level is being adjusted.

NOTE

If the output voltage from the encoder is >5 V, then the termination resistors must be disabled Pr **MM.039** to 0.

MM.039		Termination Select	
Minimum	0	Maximum	1
Default	1	Units	
Type	8 Bit User Save	Update Rate	Background read
Display Format	None	Decimal Places	0
Coding	RW		

Termination Select (Pr **MM.039**) is used to enable or disable the terminations on the position feedback interface inputs. The table below shows the functionality of this parameter.

Terminal	Input	Pr MM.039 = 0	Pr MM.039 = 1
1/2 & 3/4	A & B	Disabled	Enabled

NOTE

If the output voltage from the encoder is >5 V, then the termination resistors must be disabled Pr **MM.039** to 0.

MM.040		Error Detection Level	
Minimum	00	Maximum	11
Default	01	Units	
Type	8 Bit User Save	Update Rate	Background read
Display Format	Binary	Decimal Places	0
Coding	RW		

This parameter can be used to enable or disable position feedback trip functions as follows:

Bit	Function
0	Enabled wire break detection
1	Disable module encoder trips

It may be important to detect a break in the connections between the module and the position feedback device. This is accomplished with hardware detectors on the A and B signals that detect a wire break.

This is enabled by setting bit 0 of this parameter to 1.

When setting bit 1 of this parameter, the following trips are disabled:

- PSU Overload
- Config Changed

MM.042		Feedback Filter	
Minimum	0	Maximum	5
Default	0	Units	
Type	8 Bit User Save	Update Rate	Background read
Display Format	None	Decimal Places	0
Coding	RW, TE		

Value	Text
0	Disabled
1	1 ms
2	2 ms
3	4 ms
4	8 ms
5	16 ms

Feedback Filter (Pr **MM.042**) defines the time period for a sliding window filter that may be applied to the feedback taken from the position feedback interface. This is particularly useful in applications where the encoder is used to give speed feedback for the speed controller and where the load includes a high inertia, and so the speed controller gains are very high. Under these conditions, without a filter on the feedback, it is possible for the speed loop output to change constantly from one current limit to the other and lock the integral term of the speed controller.

MM.043		Maximum Reference	
Minimum	0	Maximum	50000
Default	1500	Units	rpm
Type	16 Bit User Save	Update Rate	Background read
Display Format	None	Decimal Places	0
Coding	RW, BU		

MM.044		Reference Scaling	
Minimum	0.000	Maximum	4.000
Default	1.000	Units	
Type	16 Bit User Save	Update Rate	Background read
Display Format	None	Decimal Places	3
Coding	RW		

MM.045		Reference	
Minimum	-100.0	Maximum	100.0
Default		Units	%
Type	16 Bit Volatile	Update Rate	4 ms write
Display Format	None	Decimal Places	1
Coding	RO, FI, ND, NC, PT		

MM.046		Reference Destination	
Minimum	0.000	Maximum	59.999
Default	0.000	Units	
Type	16 Bit User Save	Update Rate	Drive reset read
Display Format	None	Decimal Places	3
Coding	RW, DE, PT, BU		

The speed feedback from the position feedback interface can be used as a source to control a parameter. The speed feedback is scaled to give a value as a percentage of *Maximum Reference* (Pr **MM.043**) in 0.1 % units which is displayed in *Reference* (Pr **MM.045**). The value is then scaled by the *Reference Scaling* (Pr **MM.044**) and then routed to the destination defined by *Reference destination* (Pr **MM.046**). Normally the destination is updated every 4 ms, but if the destination is the *Hard Speed Reference* (Pr **03.022**), *Maximum Reference* (Pr **MM.043**) = VM_SPEED_FREQ_REF[MAX] and *Reference Scaling* (Pr **MM.044**) = 1.000 it is updated every 250 μ s. Although the hard speed reference is updated every 250 μ s internally a value in rpm is written to *Hard Speed Reference* (Pr **03.022**) every 4 ms for indication only.

MM.050		Feedback Lock	
Minimum	0	Maximum	1
Default	0	Units	
Type	1 Bit User Save	Update Rate	Background read
Display Format	None	Decimal Places	0
Coding	RW		

If *Feedback Lock* (Pr **MM.050**) = 1 then *Revolution Counter* (Pr **MM.028**), *Position* (Pr **MM.029**) and *Fine Position* (Pr **MM.030**) are not updated. If *Feedback Lock* (Pr **MM.050**) = 0 then these parameters are updated normally.

MM.056		Feedback Reverse	
Minimum	0	Maximum	1
Default	0	Units	
Type	1 Bit User Save	Update Rate	Background read
Display Format	None	Decimal Places	0
Coding	RW		

If *Feedback Reverse* (Pr **MM.056**) = 1 the position feedback is negated. This can be used to reverse the direction of the position feedback.

MM.057		Normalization Turns	
Minimum	0	Maximum	16
Default	16	Units	
Type	8 Bit User Save	Update Rate	Background read
Display Format	None	Decimal Places	0
Coding	RW		

MM.058		Normalized Position	
Minimum	-2147483648	Maximum	2147483647
Default		Units	
Type	32 Bit Volatile	Update Rate	250 μ s write
Display Format	None	Decimal Places	0
Coding	RO, ND, NC, PT		

The combination of *Revolution Counter* (Pr **MM.028**), *Position* (Pr **MM.029**) and *Fine Position* (Pr **MM.030**) give the position feedback as a 48 bit value. This position cannot be read atomically without locking the position feedback (*Feedback Lock* (Pr **MM.050**) = 1) and it cannot be used directly by the Advanced Motion Controller in the drive. It is useful to be able to create 32 bit position values that can be held by a single parameter as this value can be accessed atomically and can be used directly by the Advanced Motion Controller. *Normalization Turns* (Pr **MM.057**) defines the number of turns bits included in the *Normalized Position* (Pr **MM.058**).

How to use this guide
Safety information
Introduction
Installing the option module
Electrical installation
Getting started
Parameters
Diagnostics
Terminal data
Index

MM.070	Position Feedback Signals		
Minimum	0	Maximum	63
Default		Units	
Type	16 Bit Volatile	Update Rate	Background write
Display Format	Binary	Decimal Places	0
Coding	RO, ND, NC, PT		

Position Feedback Signals (Pr **MM.070**) shows the state of the signals from the position feedback device as given in the table below. *Position Feedback Signals* (Pr **MM.070**) is only intended as a debugging aid.

Position Feedback Signals (Pr MM.070) bits	Signals
0	A
1	B
2	Reserved
3	Reserved
4	Reserved
5	Reserved

MM.071	Error Detected		
Minimum	0	Maximum	1
Default		Units	
Type	1 Bit Volatile	Update Rate	Background write
Display Format	None	Decimal Places	0
Coding	RO, ND, NC, PT		

Error Detected (Pr **MM.071**) is set if an error has been detected with the position feedback device connected to the position interface. This parameter is useful if encoder trips have been disabled by setting bit 1 of *Error Detection Level* (Pr **MM.040**). It should be noted that this bit is not set if wire break detection is disabled with bit 0 of *Error Detection Level* (Pr **MM.040**).

How to use this guide	Safety information	Introduction	Installing the option module	Electrical installation	Getting started	Parameters	Diagnostics	Terminal data	Index
-----------------------	--------------------	--------------	------------------------------	-------------------------	-----------------	-------------------	-------------	---------------	-------

Figure 7-1 SI-Encoder Plus logic diagram

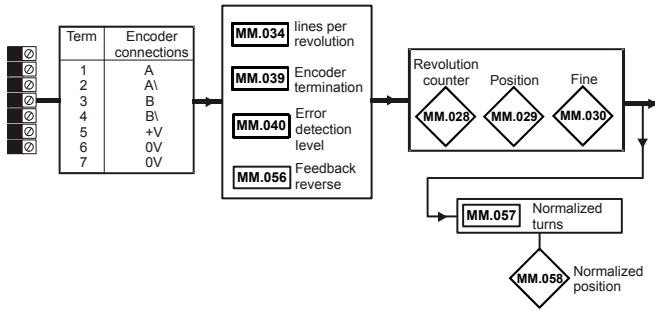

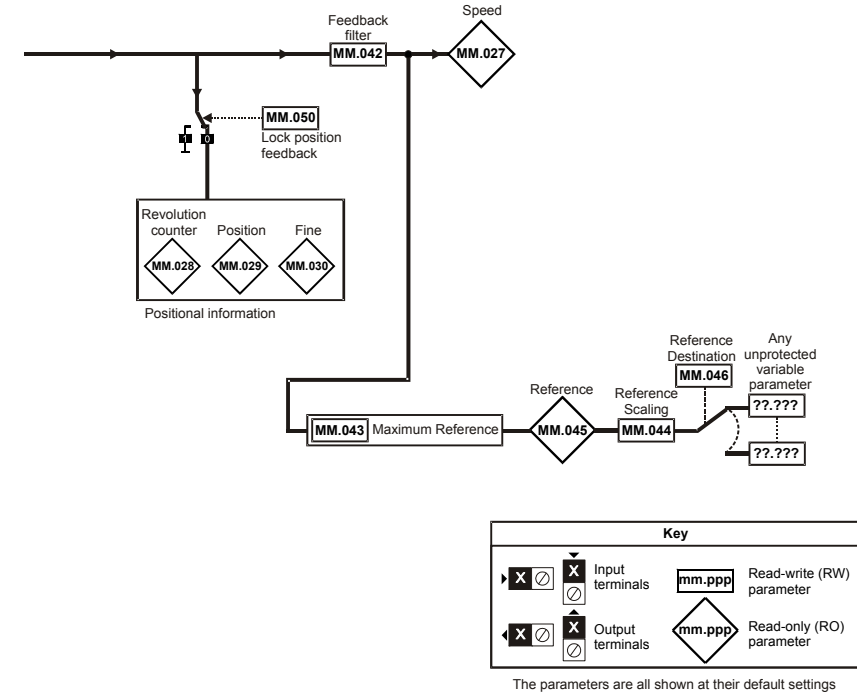

8 Diagnostics

8.1 Overview

This section provides basic diagnostic information intended to resolve the most common problems encountered when setting up an SI-Encoder option module.

8.1.1 Drive trip display codes

If the option module detects an error during operation, it will force a trip on the drive. The exact reason for the trip will be logged in the drive trip log.

The table below shows the possible trips that will be displayed on the drive when a problem is detected with the option module or when the option module initiates a trip.

Table 8-1 Drive trip display codes

Trip	Description
SlotX HF	The drive has detected that an option module is present but is unable to communicate with it due to a hardware fault.
SlotX Error	User trip generated by the option module
SlotX Not Fitted	This trip will occur if a drive slot was previously configured with an option module but on power up, no option module was detected.
SlotX Different	This trip will occur if a drive slot was previously configured with an option module but on power up, a different option module was detected. Replacing the option module with another one of the same ID number will not initiate this trip. The trip will also occur if an option module is installed to a previously unused slot.

8.1.2 Module error codes

If the option module detects an internal error during operation, it will force a trip on the drive and provide a sub-trip string for a clearer definition of the trip. The table below shows the possible module error codes.

Table 8-2 Module error codes

Value	Text	Description
200	FW Invalid	Invalid firmware for hardware revision
201	Drv unknown	Unknown drive type
202	Drv unsupported	Unsupported drive type
203	Mode unknown	Unknown drive mode
204	Mode unsupported	Unsupported drive mode
205	OHT	Over temperature
206	TO drv	The drive has not responded within the watchdog period
207	eCMP	eCMP communication failure
208	TO eCMP Slot1	eCMP communication to slot 1 timeout
209	TO eCMP Slot2	eCMP communication to slot 2 timeout
210	TO eCMP Slot3	eCMP communication to slot 3 timeout
211	TO eCMP Slot4	eCMP communication to slot 4 timeout
212	Factory Settings	Factory settings file missing
213	No Config	Configuration file missing
214	Self Test	Power on self test failed
215	Read Parameter	Parameter read failed
216	Write Parameter	Parameter write failed
217	Runtime Config	Runtime configuration error
218	File System	File system generic error
219	Config Save	Configuration file save failed

8.1.3 Encoder error codes

If the option module detects an Encoder error during operation, it will force a trip on the drive and provide a sub-trip string for a clearer definition of the trip. Table 8-3 below shows all possible encoder error codes.

Table 8-3 Encoder error codes

Value	Text	Description
100	Wire Break A	Wire break detected on A, A/ input
101	Wire Break B	Wire break detected on B, B/ input
102	PSU Overload	Encoder power supply current is too high
103	Invalid LPR	Invalid lines per revolution. Ensure that a power of 2 is used
104	Internal Error	Internal Error
105	Config Changed	Encoder configuration has changed

How to use this guide
Safety information
Introduction
Installing the option module
Electrical installation
Getting started
Parameters
Diagnostics
Terminal data
Index

9 Terminal data

9.1 Encoder inputs

1	Channel A, Frequency or Forward inputs
2	Channel A\, Frequency\ or Forward\ inputs
3	Channel B, Direction or Reverse inputs
4	Channel B\, Direction\ or Reverse\ inputs
Type	EIA 485 differential receivers
Maximum frequency	500 kHz
Line loading	<2 unit loads
Line termination components	120 Ω
Working common mode range	+12 Vdc to -7 Vdc
Absolute maximum applied voltage relative to 0 V	± 25 V
Absolute maximum applied differential voltage	± 25 V

5	Encoder Supply Voltage
Supply voltage	5 V, 8 V or 15 V
Maximum output current	300 mA for 5 V and 8 V 200 mA for 15 V

6, 7	0V Common
-------------	------------------

Index

C	Cable requirements	15
	Cautions	6
D	Diagnostics	34
E	Electrical noise	17
	Encoder circuit with galvanic isolation from encoder body	13
	Encoder inputs	36
	Encoder simulation output	18
	Encoder with galvanic isolation from motor	13
F	Features	9
	Feedback cable	15, 17
	Feedback cable connections	16
G	Galvanic isolation	12
I	Incremental encoders	10
	Installation	17
L	Line loading	36
M	Maximum frequency	36
N	No isolation	14, 15
	Notes	6
P	Power cables	16
S	Set-up parameters	9
	Shield connections	12, 15
T	Terminal data	36
	Terminal descriptions	11
	Termination resistors	18
W	Warnings	6
	Wiring connections	17

How to use this guide
Safety Information
Introduction
Installing the option module
Electrical Installation
Getting started
Parameters
Diagnostics
Terminal data
Index



0478-0127-02